



VU

VERTICAL
MILLING MACHINES

5 – 6-axis
with rotary table





TRIMILL – your partner for PORTAL MILLING MACHINES

Our main mission is to develop and manufacture portal milling machines with an excellent proportion of QUALITY – OUTPUT – RELIABILITY – PRICE. An important part of our services comprises a well-elaborated system of the warranty and after-warranty service.

A wide selection of the TRIMILL machines contains vertical and horizontal portal milling machines, which are distinguished by high rigidity and accuracy and are intended for machining of pressing tools, moulds and precise workpieces in the single-piece production.

- Machine travels from (X,Y,Z) 1.100/1.000/700 mm to 13.500/4.500/1.800 mm
- Three-, five- and multi-axis design

Partnership with our customers is based on following pillars:

- Proficiency, experience, professionalism
- Customized solutions
- Development of new solutions
- Top service and immediate availability of spare parts

Figures and facts

- 12.900 m² of the production area and more than 130 specialists in development, design, assembly and technology
- Since 2000, when our family company was established, we have been operating in the markets all over the world
- 500 portal machining centres at 200 satisfied customers in 30 countries of the world

Our customers

- Tool factories
- Forging shops
- Automotive industry
- Aerospace industry
- Energy industry

The most frequently machined materials on our machines

- Tool steel
- Aluminium alloys
- Cast iron
- Structural materials

■ TRIMILL PRINCIPLE: BOX-IN-BOX and UHPC

The box-in-box is a unique system of closed construction of the cross-beam and cross-slide with internally positioned and guided ram unit (axes Y and Z). UHPC is a high strength concrete with excellent properties for vibration damping and thermal stability of machines.

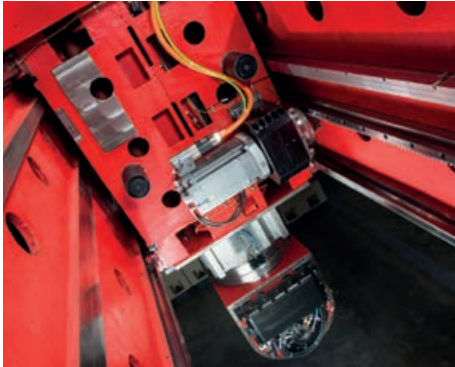

THE ADVANTAGES OF TRIMILL PRINCIPLE:

- Consistent milling results thanks to stable thermo-symmetrical arrangement on linear guideways
- Always 4 guides of the cross and vertical support for the machine, preventing the occurrence of the so-called „banana effect“ which deforms/bends the vertical support of the machine
- Increased rigidity of the machine in the X axis by +60%, in the Y axis by +30% and in the Z axis by +90%



ADVANTAGES OF USING UHPC:

- The columns and longbeams of most TRIMILL machines are made of high-strength concrete (UHPC).
- Maximum vibration damping and extended tool life
- Low thermal conductivity and high heat capacity resulting in high thermal stability of the machines
- Compressive strength ≥ 150 Mpa \Rightarrow 6 times stronger than C20/25 concrete
- Production in our own concrete plant in TRIMILL, a.s.

TRIMILL uses UHPC with the most effective damping properties for all stationary machine components, which ultimately means better surface quality, higher precision and longer tool life.

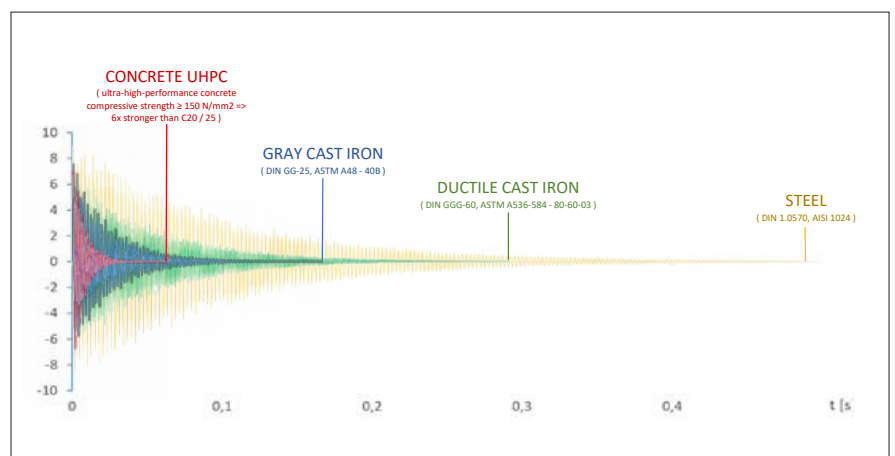

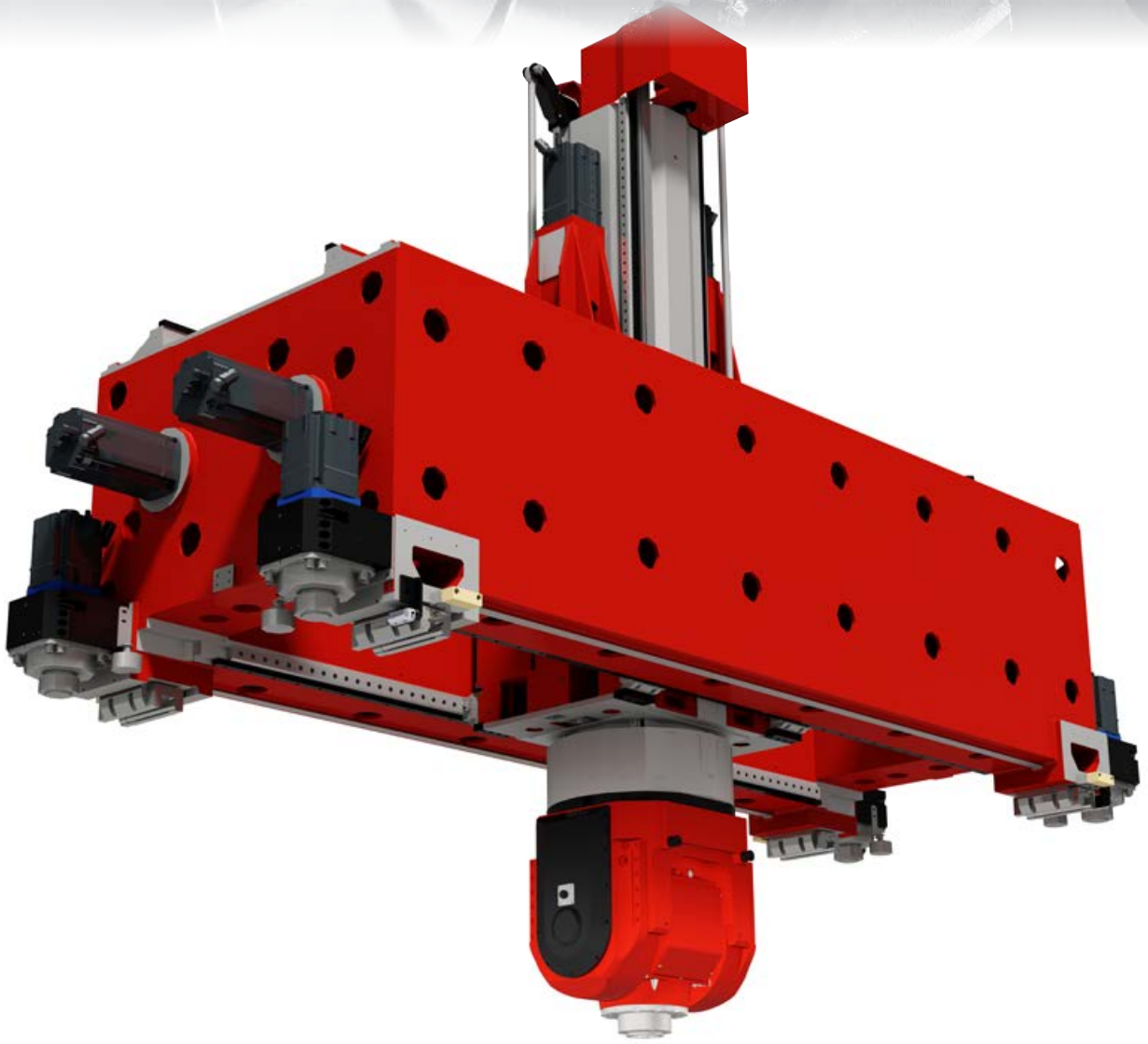

Conventional portal milling machine

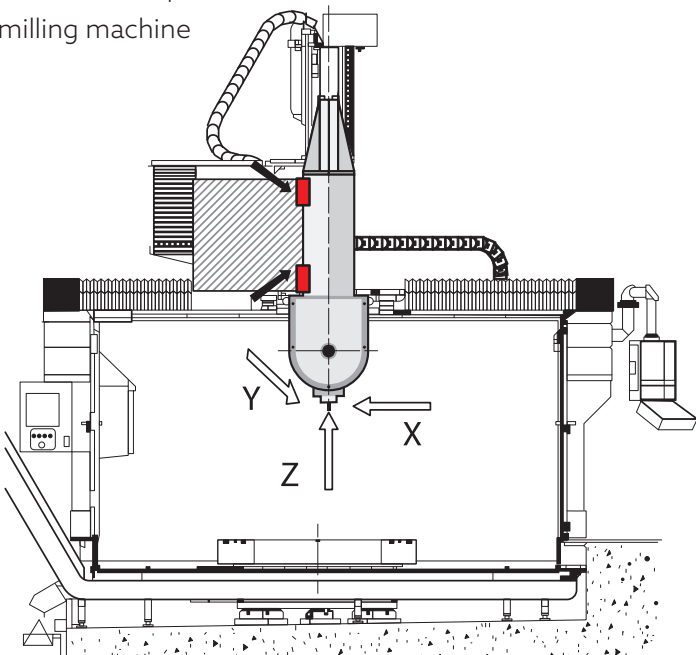

TRIMILL portal milling machine

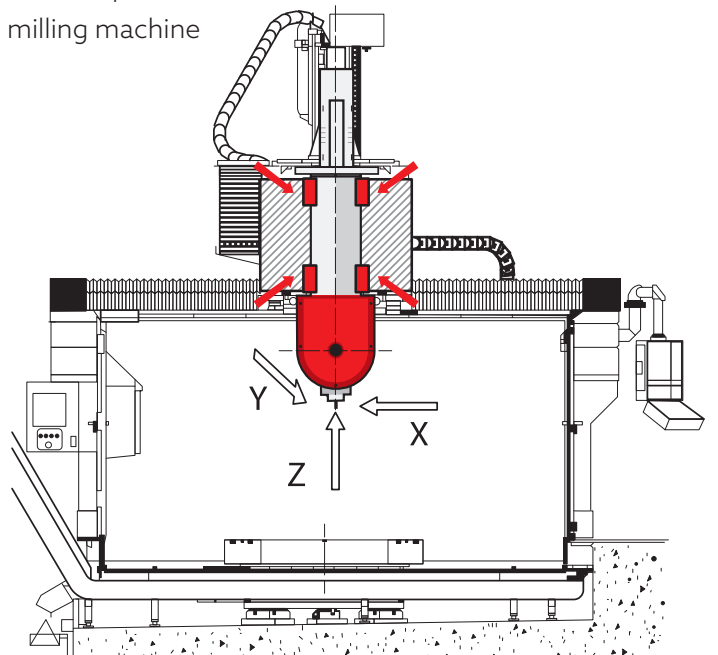

TRIMILL VU 3021



2

- 1 5-axis portal milling machine with turntable, Heidenhain TNC 640 HSCI CNC control system and 19" colour display
- 2 T30U fork milling head
- 3 Optional 6-axis machine configuration, T30C fork milling head (B and C rotary axis)
- 4 Machine turntable for workpiece clamping (C axis)



1



3

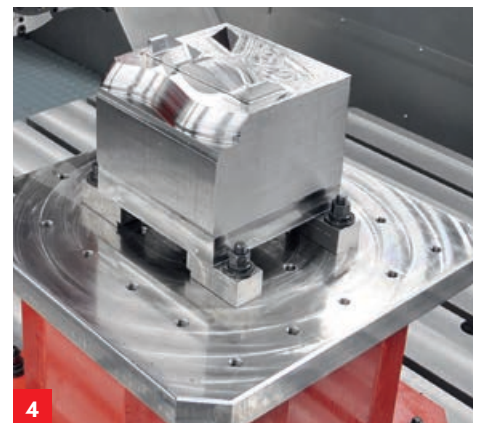

4



	X	x	Y	x	Z
VU 2216	2.200	x	1.600	x	1.200
VU 3016	3.000	x	1.600	x	1.200
VU 3021	3.000	x	2.100	x	1.200

TRIMILL HEADS

F2U

positioning

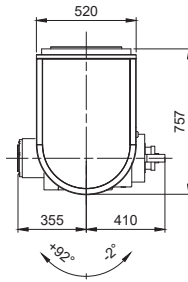
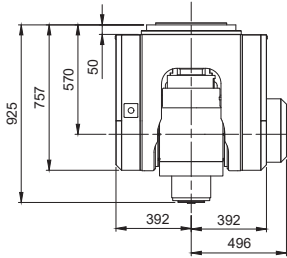
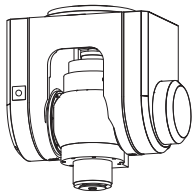
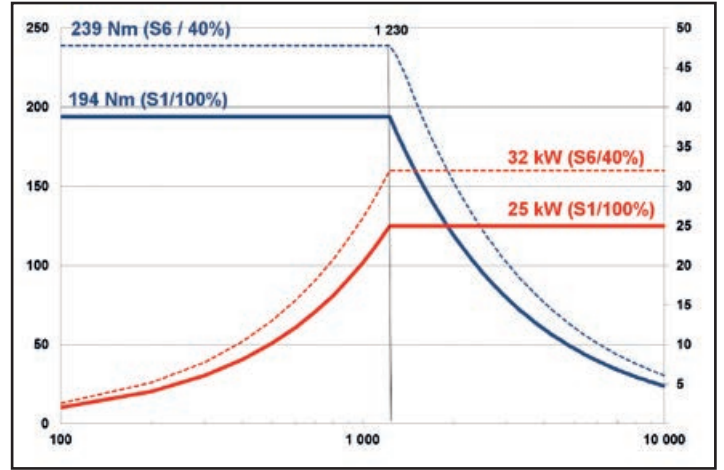

25 kW, 194 Nm, 10,000/min, HSK-A100
 B axis (milling head): -2/+92°
 B axis locking torque: 17.200 Nm
 Positioning step: 0,001°

T30U

B continuous axis

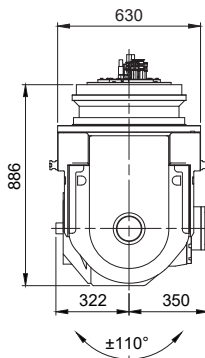
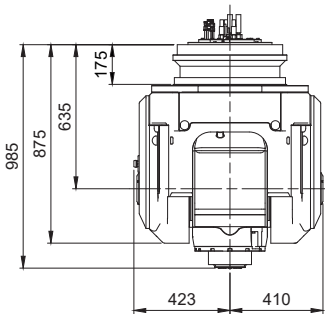
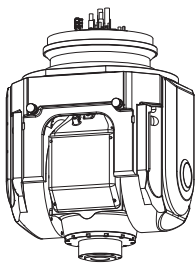
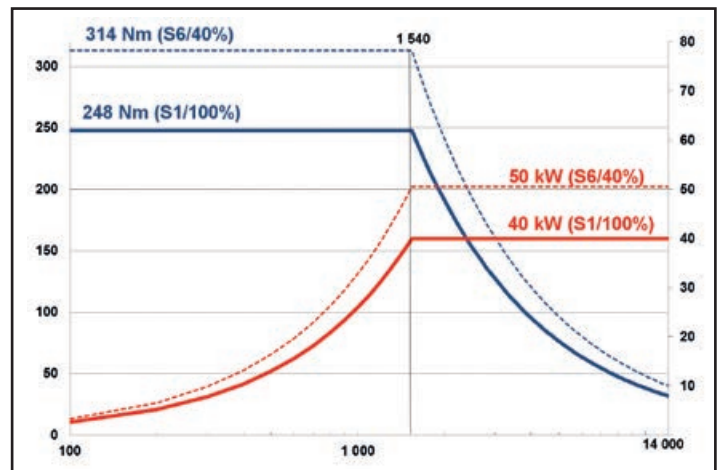

40 kW, 248 Nm, 14,000/min, HSK-A100
 B axis (milling head): +/-100°
 B axis locking torque: 8.000 Nm

T30C

continuous

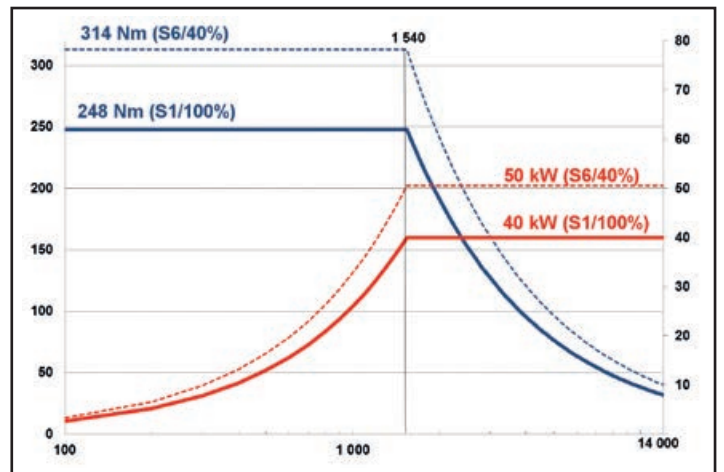
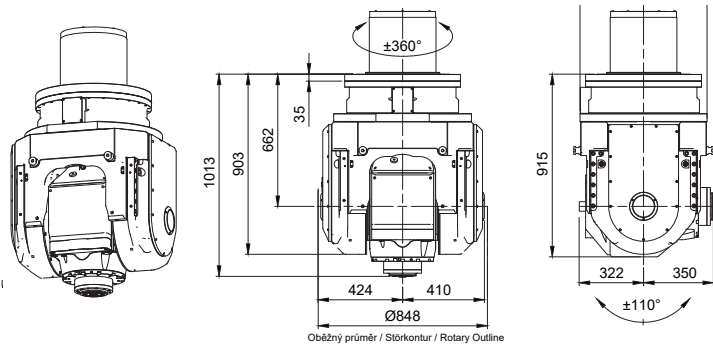

40 kW, 248 Nm, 14.000/min, HSK-A100

B axis (milling head): $\pm 100^\circ$

C axis (milling head): $\pm 240^\circ$

B axis locking torque: 8.000 Nm

C axis locking torque: 8.000 Nm

F4F / F5U

continuous / B positioning axis

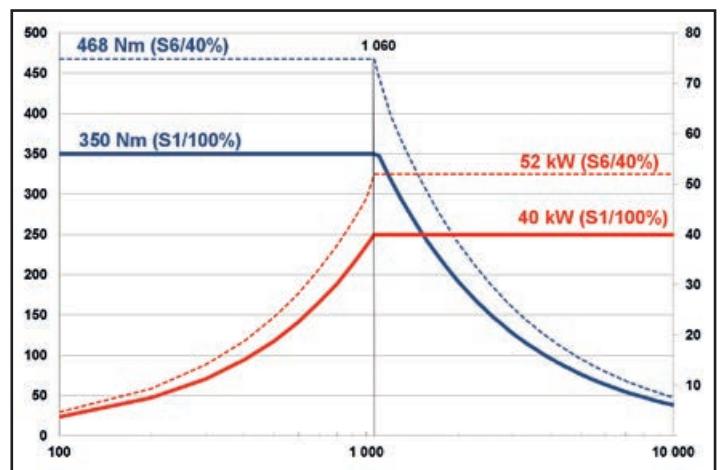
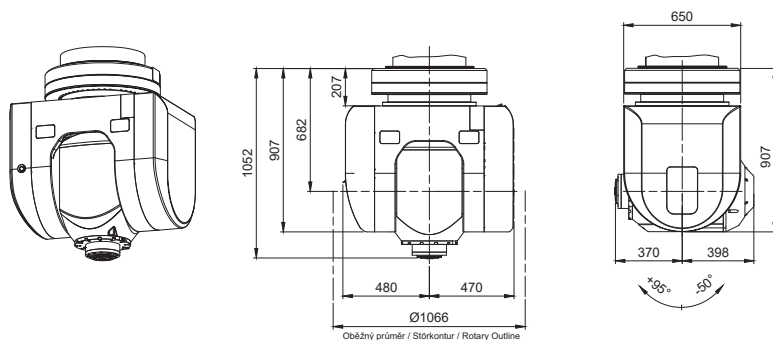

40 kW, 350 Nm, 10.000/min, HSK-A100

B axis (milling head): $-50/+95^\circ$

C axis (milling head): $\pm 240^\circ$

F4 U - B continuous axis

F5 U - B continuous axis (step 0,001°)

B axis locking torque: 17.200 Nm

* 4U / F5U milling heads optional
for the VU 3525 machine type only

TRIMILL HEADS

T21U

B continuous axis

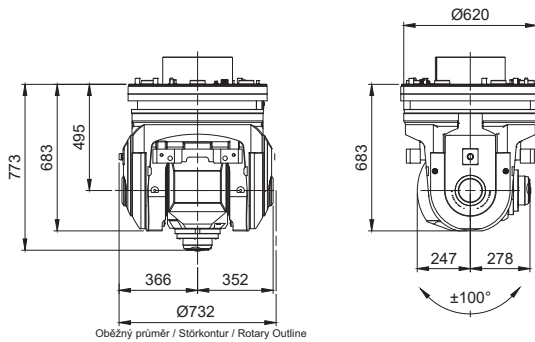
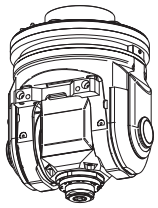
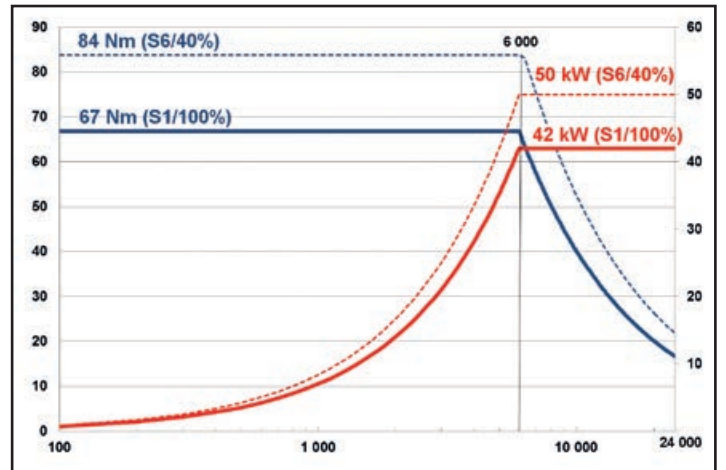

Oběžný průměr / Störkontur / Rotary Outline

42 kW, 67 Nm, 24.000/min, HSK-A63

B axis (milling head): +/-100°

B axis locking torque: 4.000 Nm

T21C

continuous

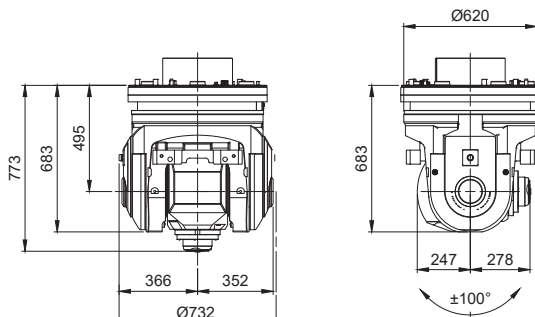
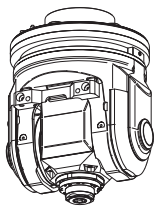
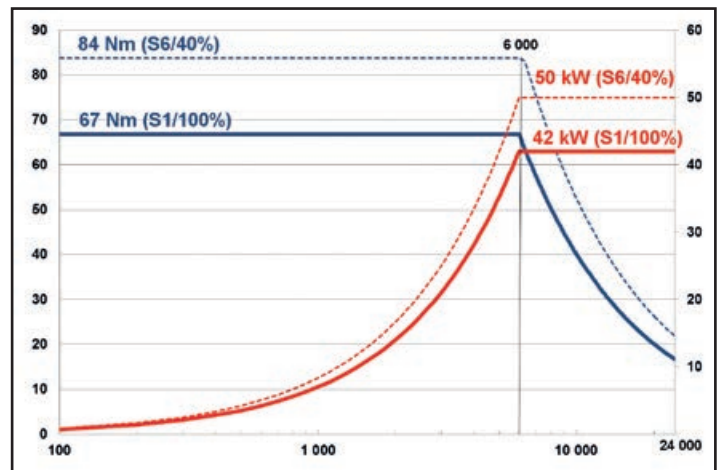

Oběžný průměr / Störkontur / Rotary Outline

42 kW, 67 Nm, 24.000/min, HSK-A63

B axis (milling head): +/-100°

C axis (milling head): +/-240°

B axis locking torque: 4.000 Nm

C axis locking torque: 4.000 Nm

T30C CSC

continuous

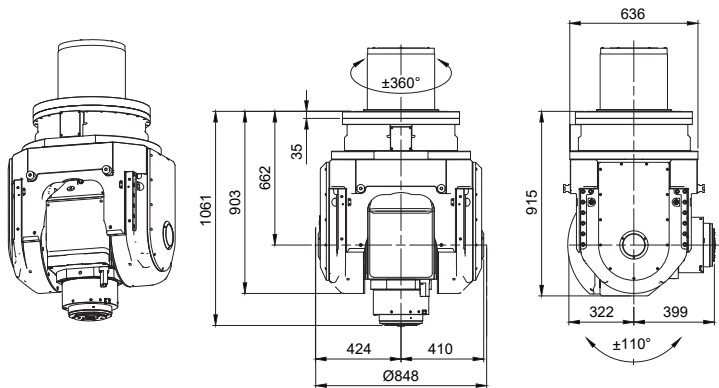
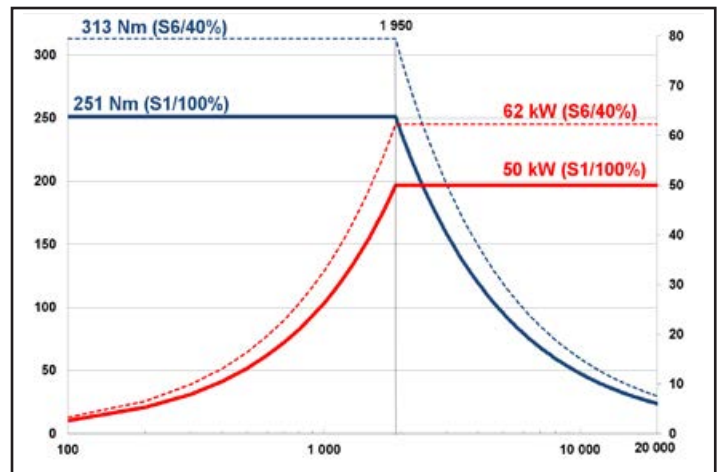

Oběžný průměr / Störkontur / Rotary Outline

50kW, 251 Nm, 20.000/min, HSK-A100

B axis (milling head): +/-100°

C axis (milling head): +/-240°

B axis locking torque: 8.000 Nm

C axis locking torque: 8.000 Nm

T15C

continuous

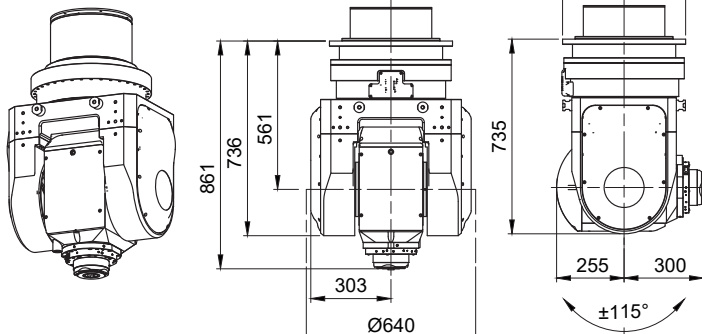
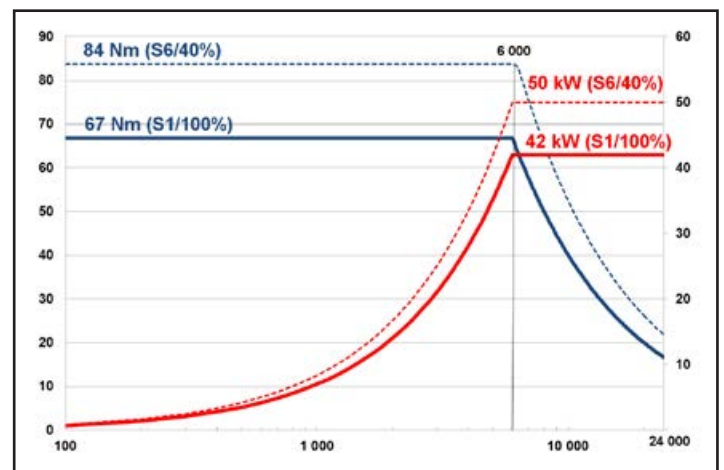

Oběžný průměr / Störkontur / Rotary Outline

T15C

42 kW, 67 Nm, 24.000 ot/min, HSK-A63

B axis (milling head): +/-115°

C axis (milling head): +/-360°

B axis locking torque: 5.400 Nm

C axis locking torque: 6.120 Nm

T15C

50 kW, 96 Nm, 15.000 ot/min, HSK-A100

B axis (milling head): +/-115°

C axis (milling head): +/-360°

B axis locking torque: 5.400 Nm

C axis locking torque: 6.120 Nm

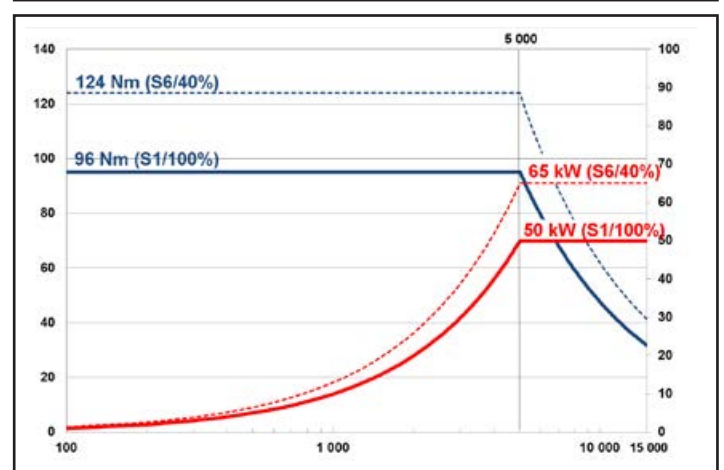

TRIMILL HEADS

U2C positioning

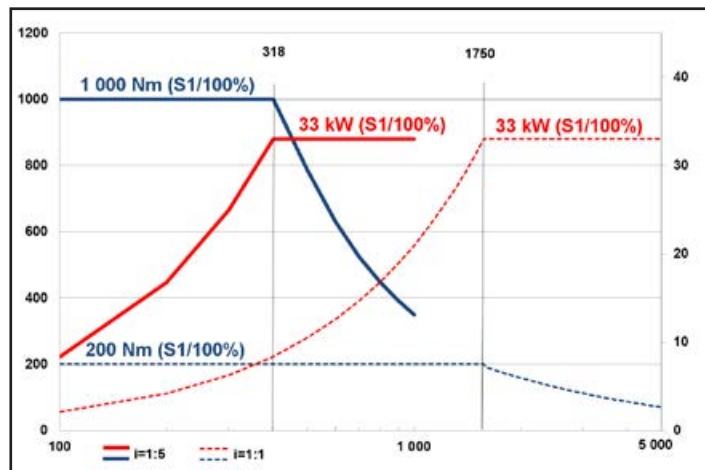
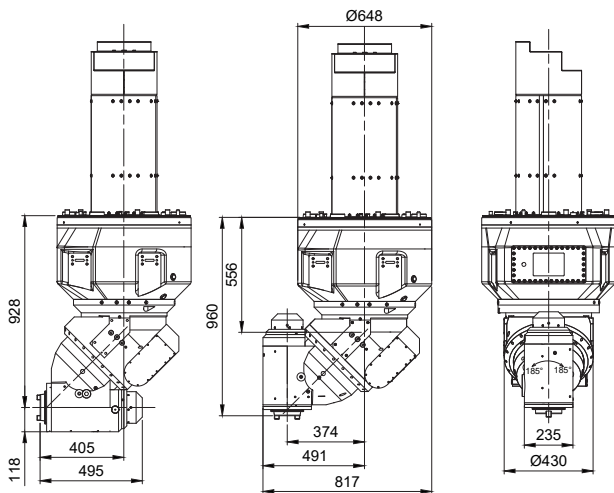

33 kW, 1.000 Nm, 5.000/min
 A axis (milling head): +/- 185°
 A axis locking torque: 3.000 Nm
 C axis locking torque: 6.500 Nm
 Polohovací krok: 0,001°
 Upínací kužel: SK-50, HSK-A100

U3C continuous

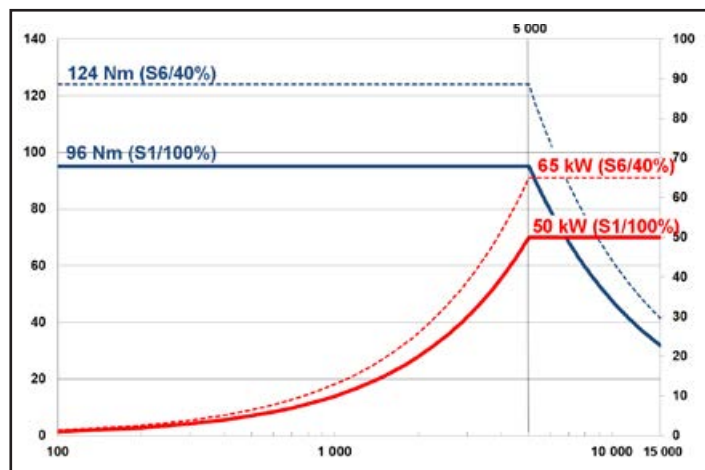
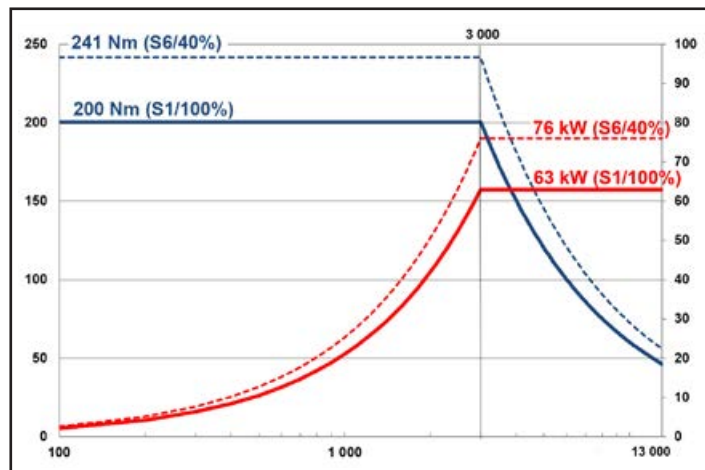
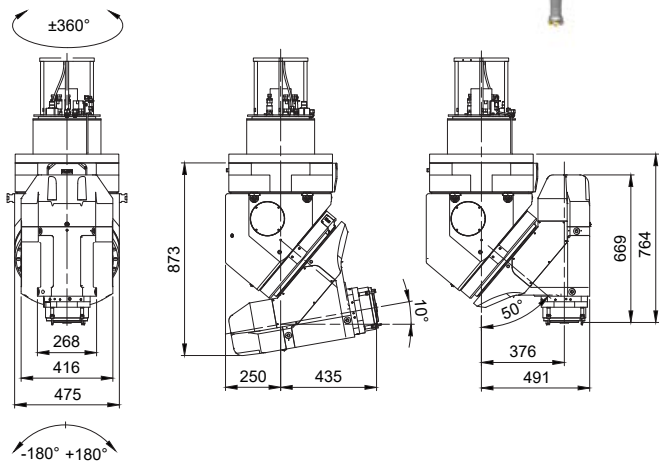

42 kW, 67 Nm, 24.000/min
 A axis (milling head): +/- 185°
 C axis (milling head): +/- 360°
 A axis locking torque: 5.400 Nm
 C axis locking torque: 5.400 Nm
 Upínací kužel: HSK-A63

63 kW, 200 Nm, 13.000/min
 A axis (milling head): +/- 185°
 C axis (milling head): +/- 360°
 A axis locking torque: 5.400 Nm
 C axis locking torque: 5.400 Nm
 Upínací kužel: HSK-A100



TRIMILL VU 3525



- 1 Very compact VU 3525 machine with a large working area and minimal floor space occupied
- 2 Automatic tool magazine for 32/50 tools
- 3 The machine is intended for 5-side roughing and finishing during single clamping
- 4 Optional T30C fork milling head for continuous milling

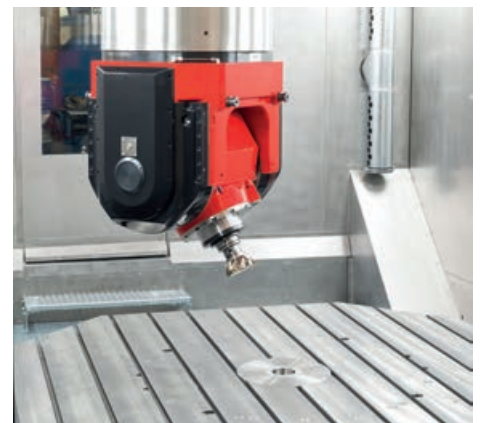



	X	x	Y	x	Z
VU 3525	3.500	x	2.500	x	1.500

■ STANDARD MACHINE PARAMETERS

		VU 2216	VU 3016	VU 3021	VU 3525
Travels					
The X-axis	mm	2.200	3.000	3.000	3.500
Y axis	mm	1.600	1.600	2.100	2.500
Z axis	mm	1.200	1.200	1.200	1.500
Feed rate	mm/min	40.000			
Fixed machine table	mm	1.800 x 1.800	1.800 x 1.800	2.300 x 2.300	2.300 x 2.300
Workpiece weight	kg	26.000	26.000	25.000	25.000
Acceleration	m/s ²	4	4	4	3
Machine dimensions					
Length	mm	6.525	7.275	8.230	8.065
Width	mm	4.870	5.295	5.795	7.005
Height	mm	5.160	5.160	5.160	6.245
Machine weight approx.	kg	69.700	72.700	75.200	91.600



TRIMILL®
machine tools

MFR 180621 YCHSK-ASB
Made in
Fischer
Fischer and Fischer Group
P.O. Box 100
44100

FISCHER

Solutions for both large and small companies.
Always tailor-made.

gorenje



SIEMENS



ŠKODA



autoneum



MouldPro

TRIMILL Your partner for PORTAL MILLING MACHINES

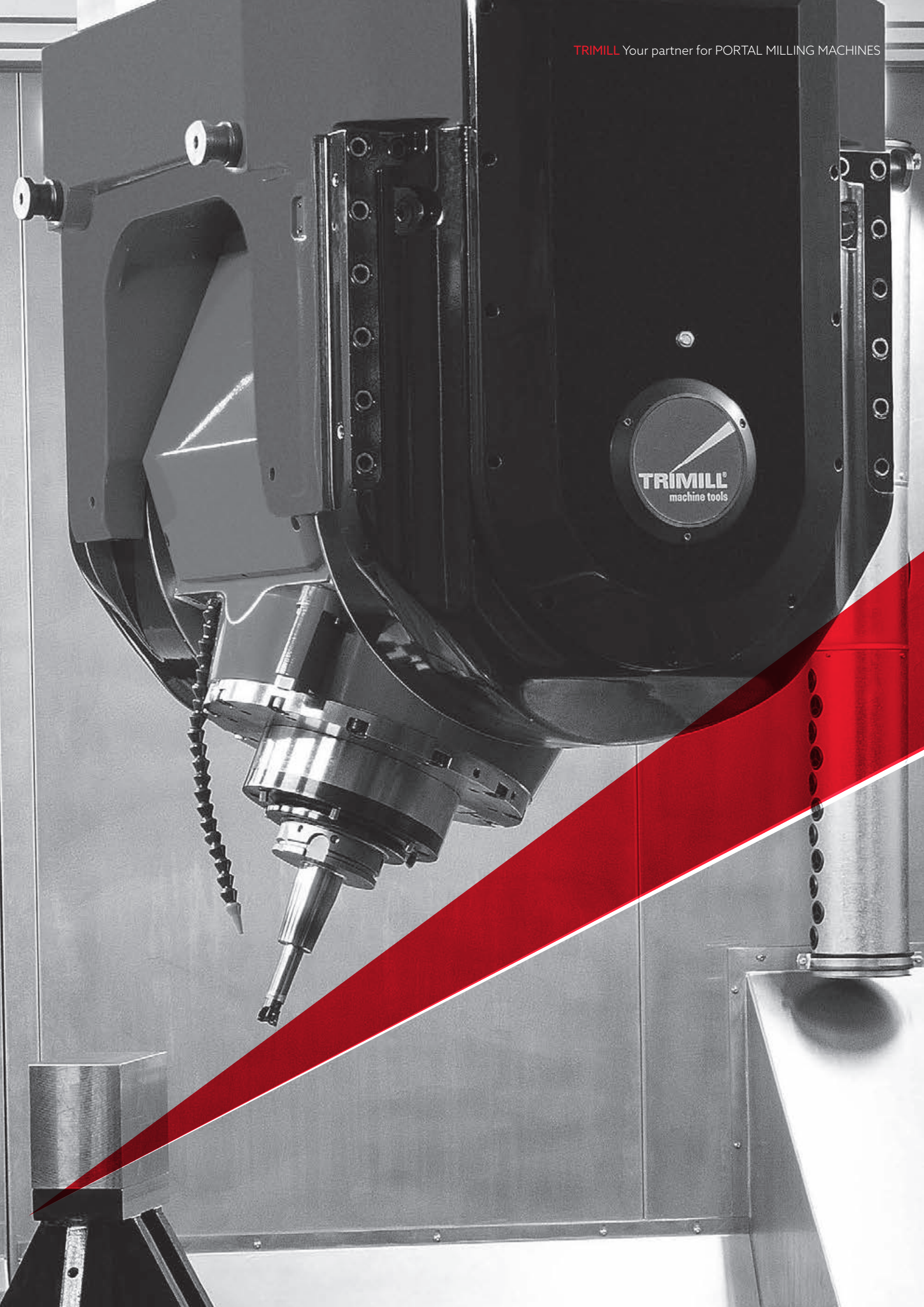

STANDARD MACHINE COMPONENTS

STANDARD COMPONENTS

MAKER

Electric spindle	Weiss - Germany, Fischer - Switzerland, Peron - Italy, HSD - Italy
Control system	Heidenhain, Siemens - Germany
Electric motors	Siemens - Germany
Measuring	Heidenhain
Toothed combs	Schneeberger - Germany
Linear management	THK - Japan, Schneeberger - Germany, INA
Table	Fibro - Germany
Electrical switchboard	Rittal - Germany
Cooling unit	Rittal - Germany, Eurocold - Italy

OPTIONAL EQUIPMENT (SELECTION)

TRIMILL Inform

TRIMILL Teleservice

Active temperature stabilization of the machine

Tool magazine ATC 32, ATC 50, ATC 90+

Tool cooling by external + internal liquid

Workpiece probe

Tool probe

Oil mist micro lubrication - internal, external

Video system with display and 2 controllable color cameras

TRIMILL - Kinematics

HR 550 - wireless hand control

Electrically operated top cover of the machine

Extraction of oil mist and cooling emulsion



TRIMILL Inform



TRIMILL Teleservis



ATC 50 tool magazine



Tool cooling liquid external + internal



Workpiece probe



Tool probe



Micro lubrication with oil fog - inner, outer



CCTV System



TRIMILL - Kinematics



HR 550 - wireless hand control



Electrically operated upper machine cover



Oil mist extraction and cooling emulsions



Oil mist extraction and cooling emulsions

Czech Republic

TRIMILL, a.s.

Dlouhé díly 447

763 02 Zlín-Louky

Czech Republic

Phone: +420 577 112 111

info@trimill.cz

www.trimill.cz

Czech Republic

TRIMILL, a.s.

Jasenice 2061

755 01 Vsetín

Czech Republic

Phone: +420 577 112 171

info@trimill.cz

www.trimill.cz

Germany

TRIMILL GmbH

Zeissstrasse 6

32052 Herford

Germany

Phone: +49 5221 69 448-0

info@trimill.de

www.trimill.de